

FRONTIER

Bagmaker

Best-in-Class Performance, Simplicity and Reliability for Emerging Markets

Reliable and space-efficient, the **Frontier** is the updated design of the Compak, one of the industry's leading economical bagmakers, now with networking and remote diagnostic capability for rapid support whenever and wherever you need it.

The Frontier is designed to be:

- Simple to operate and maintain
- Sanitary and easy to clean
- Simple to configure and change
- A reliable, cost-effective investment

The Frontier features our sanitary, open-design Flex-Mount frame in a compact footprint. Our Insight® color graphic touchscreen interface is multilingual and easy to learn. With minimal adjustments and a recipe-based program package, size changeover can be accomplished in under ten minutes. Our newly-designed ergonomic former base diverts formers to one side for easier and safer former changes. We used globally-available components and advanced “off-the-shelf” electronics and servo motors for supreme reliability and lowered maintenance costs.

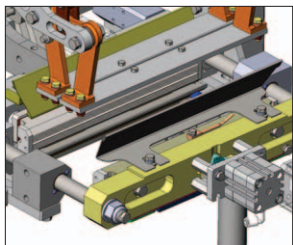

Woodman Exclusive

Available “snack food features” include programmable product stripping and our exclusive product clamp and settler to virtually eliminate product-in-seal contamination and reduce bag waste.



Easy Operation

KW's industry-leading Insight® color graphic touch screen HMI is intuitive and self tutoring. Automatic programming eliminates operator error and ensures consistent performance regardless of shift or operator skill. Enhanced diagnostics are standard.

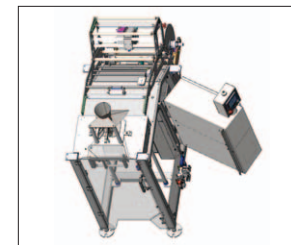

Maximum Access

Our Flex-Mount tubular frame design is strong, compact and wide open for sanitation. The electrical enclosure swings away from the frame to allow total access to the machine interior from either side. It can also self-support your filler without a mezzanine.

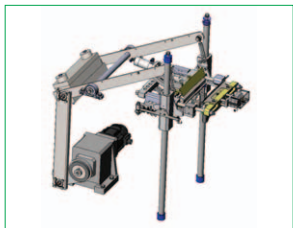

New Sealing System

Our proven and reliable “draw bar” film advance has been upgraded with a new high-force sealing system to positively handle the toughest films with confidence and higher seal integrity.

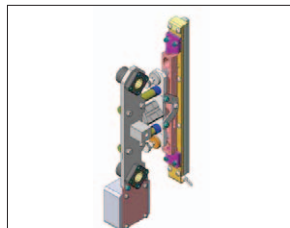

Modular Maintenance

We designed the Frontier from the ground up to ensure maximum uptime. All critical components can be swapped out in minutes with simple tools and quick-disconnect wiring for rapid recovery.

FRONTIER

Bagmaker

PERFORMANCE

SPEED: Variable from 10 to 80 bags per minute
Actual speed depends upon product characteristics, bag size, packaging material and filling system.

BAG SIZE RANGE:	MIN.	MAX.
Width	2.5" (63.5 mm)*	9.0" (228 mm)
Length	3.0" (76 mm)	15" (381 mm)

BAG STYLES: Pillow Pouch (fin or lap seal), Gusseted

**Note: Smaller bag widths, down to 2-1/8" (54 mm), may be possible, and would be subject to additional charges.*

OPERATING REQUIREMENTS

ELECTRICAL: 230 VAC ±5%, 1-Phase w/ ground (PE), 50/60 Hz
NORMAL POWER CONSUMPTION: 3kVA
SERVICE REQUIRED: 30 amps @ 230 VAC

AIR: 3.6 CFM (102 L/min) at 75 psi (5.2 bar) for 80 bpm
 (25 CFM / 707 L/min at startup)

ENVIRONMENT: Normal ambient temp. 50–100°F
 (10–38°C), less than 90% non-condensing humidity.

FILM CORE INSIDE DIAMETER: 3" (76mm)
Max. FILM ROLL OUTSIDE DIAMETER: 13" (330 mm)
Max. FILM ROLL WEIGHT: 50 lbs (22 kg)

CONSTRUCTION

Welded tubular stainless-steel-powder-coated steel frame with Lexan guarding.

Approximate shipping weight: 1750 lbs (800 kg)

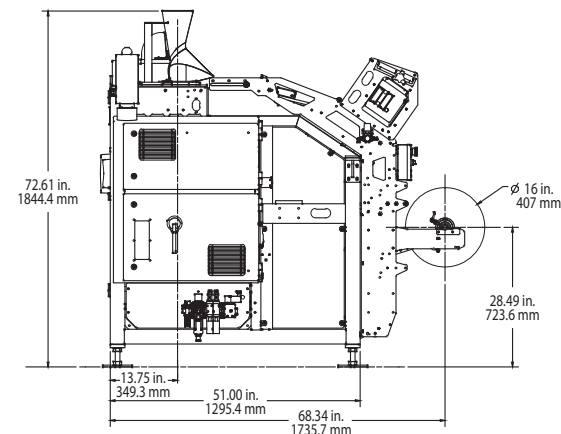
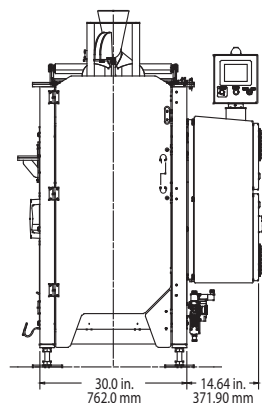
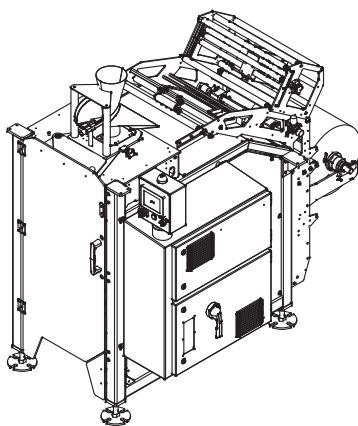

STANDARD FEATURES

- Intermittent motion profile
- Proven servo-driven reciprocating carriage
- Yaskawa-based PLC control functions
- Programmable pneumatic product stripping
- Quick-change ergonomic former assembly
- Open-design tubular steel Flex-Mount frame
- Electronic registration control
- Motorized film tracking
- Insight® Color Graphic Touch Screen HMI
- Performance reporting, diagnostics and troubleshooting
- Automatic program setup
- Instant program changeover
- Electronic registration control
- Full safety guarding and interlocks
- Ancillary device isolated interface strip
- 230-volt convenience outlet and USB data port
- CE / NFPA / NEC approved electricals
- Meets Category 3 safety requirements

OPTIONAL FEATURES

- Product clamp and settler (snack food feature)
- Simple gusset tuckers
- Product pocker
- Hole-punch jaws
- Quick-change jaws
- Programmed nitrogen flush
- Woodman Codeline TTO printer
- Perforated bag strip
- Special end-seal configurations
- MGuard® remote diagnostics and connectivity
- Expandable ethernet capability
- Other custom requirements

KLKLOK • WOODMAN®

5224 Snapfinger Woods Drive
 Decatur, GA 30035 USA
 Tel +1-770-981-5200 Fax +1-770-987-7160
 kwmarketing@kliklokwoodman.com
 www.kliklokwoodman.com

Western Drive, Hengrove Park Estate
 Whitchurch, Bristol, BS14 0AY, UK
 Tel +44-1275-836131 Fax +44-1275-891754
 sales@kliklok-int.com
 www.kliklok-int.com